



Bulgarian National English
1st Annual
2011



What is a Spelling Bee?

A *Spelling Bee* is a competition for students to spell words aloud letter by letter. Students are eliminated if they spell a word incorrectly.

Why do we call the competition a *Spelling Bee*?

Several theories exist as to why the term *Bee* is used to refer to a spelling competition. Many believe that the similarity between the social interactions among humans and social interactions among bees are similar to one another. Recently, however, scientists have denounced this theory, and instead claim that the word "bee" derives from the Old English word "bene", which means "prayer" or "service" and is associated with a famous word "boon" meaning "grace."

Others suggest that the word "bee" is an abbreviated form of the English word "been", which refers to "voluntary assistance provided by neighbors toward the accomplishment of a particular task." Nevertheless, no one is precisely sure where the term *Bee*, as used in the context of spelling, originated.¹

The Scripps sponsored National Spelling Bee is held annually in the United States. This competition first took place in Louisville, Ky., in 1925. It hosted just nine participants in its inaugural year, and has since grown exponentially to include a very competitive and diverse group of young American students. This past year, in its 83rd competition, over 11 million students competed for the coveted title of "National Spelling Bee Champion." The competition has served as an inspiration to many countries across the world to begin their own National English language spelling competitions. Some of these countries include Canada, Armenia, China, and several countries in Western Europe.

¹ "Origin of the Term *Spelling Bee*", *Scripps National Spelling Bee*, <http://www.spellingbee.com/origin-term-spelling-bee>, 2010. All information regarding the Scripps National Spelling Bee is cited from this source



ON-LINE RESOURCES

Below are links to different English language spelling bees throughout the world:

<http://www.spellingbee.com/> - official site of the Scripps National Spelling Bee

<http://www.marrsspellingbee.com/> - this spelling bee began in 2003, and has become the largest spelling competition in Asia for students. Currently, it hosts over 3,000,000 participants at the local level from more than 1000 schools. This competition is held in places such as India, Nepal, and China.

<http://www.timesspellingbee.co.uk/> - This spelling bee began in the United Kingdom in 2008. Schools from England, Wales, Scotland, and Northern Ireland

<http://www.dawnspellingbee.com/> - This spelling bee has been conducted in Pakistan since 2005.

<http://www.southasianspellingbee.com/>

Below are links to different news video clips of the Scripps National Spelling Bee:

<http://www.youtube.com/watch?v=SnKKpsuuF80&feature=related>

<http://www.youtube.com/watch?v=ShI53aLLLyY&feature=related>

http://www.youtube.com/watch?v=P2w3W5kbOzw&feature=player_embedded

Below are several links to funny spelling bee videos:

<http://www.youtube.com/watch?v=VjzrNWPuI9E>

<http://www.youtube.com/watch?v=gSIYSzqksU&feature=related>

<http://www.youtube.com/watch?v=A8jwp5ou5hE>

Bulgarian National English Spelling Bee Activities to Improve Students' Spelling

Purpose of Activities: To provide students with the opportunity to practice spelling aloud in front of classmates and adults.

Why: It is important that students become comfortable and confident when spelling words aloud in front of others before the official competition begins. Practice will help to alleviate anxiety that could otherwise prevent students from performing well during competition.

Practice Time: It is recommended that teachers and volunteers allocate at least five to ten minutes of class time several times a week. You may implement practice time during the beginning of class or towards the end of class. Practice time may vary depending on the length of any given school lesson. In such cases, it is advisable to develop a more consistent practice routine by starting an after school spelling group. In general, there are many different options when deciding how to allocate time for practice. It is up to the teachers and volunteers to decide which methods will work best for you and your students.

Note: Given time constraints during school, it may not be possible for each student to have the opportunity to practice spelling out loud. So, remember that whether or not students are spelling out loud or just quietly working on a spelling worksheet, the most important thing is that the students are practicing in any capacity.

Listed below are several suggestions and descriptions for games and activities that are useful and fun when learning a new language.

Games:

Cards: Create a deck of alphabet cards. On each card write one letter of the alphabet and leave the opposite side blank. Place or spread the deck of cards face down on a table. Students may randomly select two to three cards from which they must think of one word that includes each letter selected. The word may include the same letter more than once. For example, if a student draws a card with an "E" on it, he/she may choose to spell a word that includes more than one "E."

Hangman: This game requires an "Executioner" and "Jury". Select one student from the class to be the Executioner. The rest of the class will make up the Jury. The Executioner must think of a word and proceed to draw the following:

- 1) Draw a post and a noose on the chalkboard (see below in Diagram A1 and B1)
- 2) Draw the equivalent number of blank spaces as there are letters in the word
 - a. In the diagrams below the word chosen is "CAR", therefore, three blank spaces next to the hanging post have been drawn.

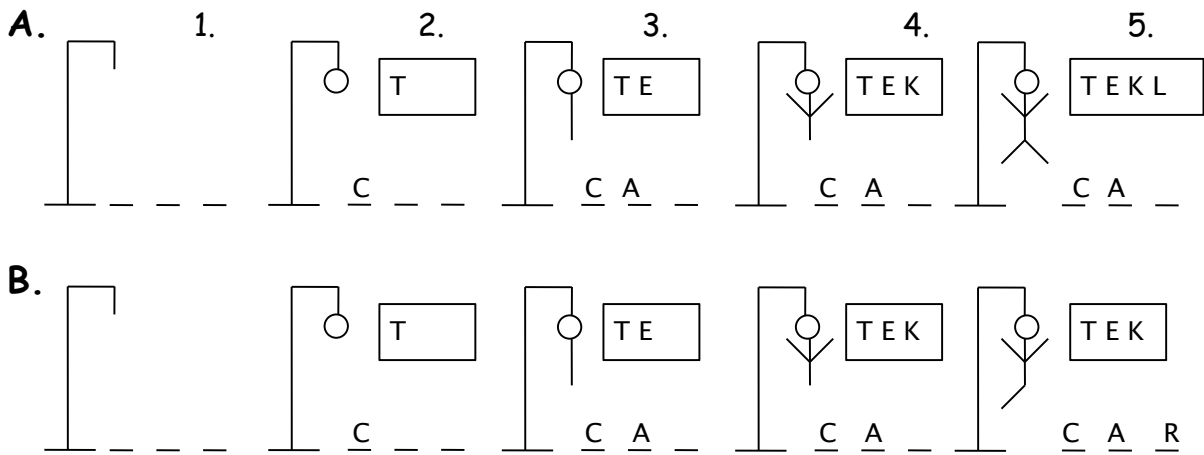

When the Executioner has finished setting up, he/she will call one person from the Jury at a time to guess a letter. In Diagram A2 you can see that a head is drawn from the noose. A Jury member incorrectly guessed that the letter "T" is part of the word. The Executioner must write down each incorrectly guessed letter (as shown above in Diagrams A and B). This will prevent confusion as to which letters has already been guessed. The Jury continues to guess letters until there is a winner.

Diagram A is an example of the Executioner winning - the body of the Hangman was completely drawn before the Jury was able to guess the correct word.

Diagram B is an example of the Jury winning - the word "CAR" is completed before the drawing of the Hangman's body has been completed.

In general, the Hangman is not completely "hanged" until his head, body, arms, and legs are drawn. However, you can modify the rules to allow students more guesses. You can add the hair, eyes, nose, mouth, and hands.

Bingo: Select at least 24 different spelling words to use for this game. Write each word on the board. Hand each student a BINGO card along with tokens used to cover up the spaces of the card. Students must fill in the spaces of the BINGO card with

each of the 24 words. Once the students have filled in their cards, you need to cover or erase the list of words on the board.

BINGO

| | | | | |
|-------|--------|-------|--------|-------|
| Car | Truck | Milk | Rabbit | Dog |
| Train | Heart | Lucky | Star | Hard |
| Under | Quiet | FREE | Light | Table |
| Chair | Strong | Funny | Short | Torn |
| Bell | Look | Zebra | Yellow | Candy |

To begin playing, call a student to stand where he/she cannot see the BINGO card. Randomly choose one of the spelling words for the student to spell out loud. If the student correctly spells the word, then each person may use a token to cover up the word. If the student misspells the word, then no one is allowed to cover the word until it is chosen again and is spelled

correctly. Continue to choose different students to stand and spell each word out loud until someone has called out "BINGO"!

A student must cover five spaces in a row before he/she can say "BINGO!" (Diagram D below). The student must then repeat the five words to confirm that these words were in fact previously selected by the teacher and spelled correctly. Once confirmed, the student must stand in front of the class and correctly spell each of the five words. If the student correctly spells each word, then he/she is a winner. If the student does not correctly spell each of the five words, then the game continues until another student calls out "BINGO!" and is able to correctly spell each of the five words.

Diagrams C and D are examples of BINGO cards. Diagram C shows what a card should look like prior to playing. Diagram D shows what a "BINGO!" looks like. Notice that there is a FREE space located in the center of the card. This space can be covered up at any point during the game and is meant to make the game a little easier. Should a string of covered spaces pass through the middle, the FREE space is one less word that needs to be spelled to get a BINGO.

| BINGO | | | | |
|-------|--------|-------|--------|-------|
| Car | Truck | Milk | Rabbit | Dog |
| Train | Heart | Lucky | Star | Hard |
| Under | Quiet | FREE | Light | Table |
| Chair | Strong | Funny | Short | Torn |
| Bell | Look | Zebra | Yellow | Candy |

Note: Bingo can be a string of five covered spaces in many directions:

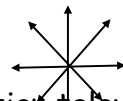

Wheel of Fortune: Adapted from the popular American and Bulgarian television show, this game can be played in the classroom as well.

Materials Needed:

Cardboard - to make the wheel
*Colored Paper - to make the numbers

Scissors
Tape/Glue - to attach numbers to board
Dice (2 cubes)

*You may use markers to draw numbers on the cardboard instead of cutting out numbers if this is easier for you

Tokens - you can use beans, coins, or anything to represent each player

Instead of using a spinning wheel, construct a wheel out of cardboard or paper and fill in different point values for each space on the wheel using either colored construction paper or markers. Don't forget to add a "B" for "Bankrupt" and a "T" for "Lose a Turn".

Assign each player a token. Players must start at the same place on the wheel and move in a clockwise direction. The first player begins by rolling the pair of dice. The player must move his/her token the exact number of spaces shown on the dice. If the player lands on a number, he/she may guess a letter. A correct guess means that the player may either roll again or try to solve the puzzle. If the player rolls the dice again, then his/her turn proceeds as before. If the player incorrectly attempts to solve the puzzle then he/she loses a turn. If the player correctly solves the puzzle, then only his/her points from the round will be counted towards his/her final score. Players who did not solve the puzzle will lose their points accumulated during the round. It is up to the teacher to decide how many rounds will be played.

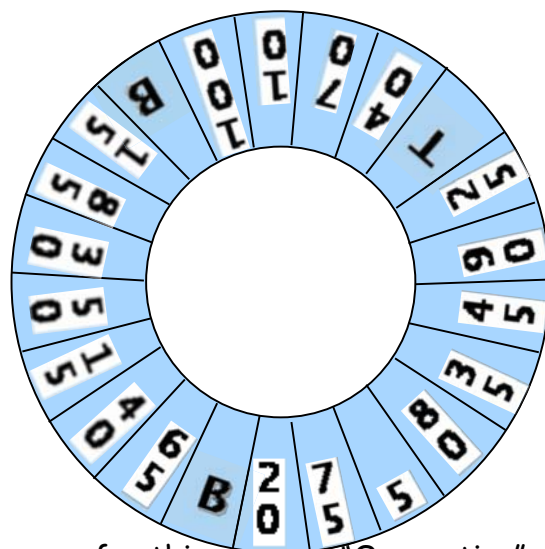
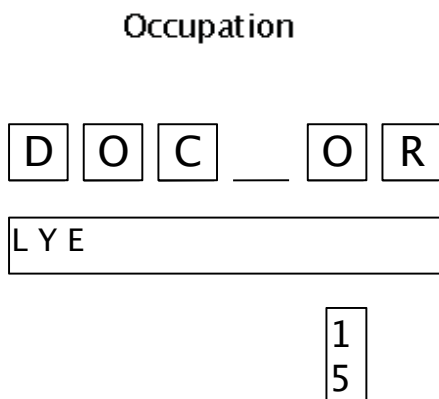

As you can see in the above diagram, the category for this round is "Occupation". The word is "Doctor." Notice that there is a long rectangular box beneath the word "Doctor" with the letters "L", "Y", and "E." These are letters that have already been incorrectly guessed. Keeping track of previously guessed letters makes it easier for students to know which letters are left.

Jeopardy: adapted from the popular American television show, this game can easily be played in the classroom. Make four to six categories of different words. Some examples of categories are: "Jobs/Occupations"; "Food"; "Beverages/Drinks"; and "Feelings." Make at least five different words for each of these categories. If the category is "Jobs/Occupations" you can make cards that say, "Doctor," "Lawyer," "Nurse," etc. If you choose the category "Feelings" you can make cards that say, "Happy," "Sad," "Depressed," etc. Each of the cards under the different categories should be assigned a point value. For example, under the "Feelings" category, the word "Sad" might be valued at 100, but the word "Depressed" might be valued at 400. Split the class into different teams.

| Jobs/Occupation | Food | Beverages/Drinks | Feelings | Sports |
|-----------------|------|------------------|----------|--------|
| 100 | 100 | 100 | 100 | 100 |
| 200 | 200 | 200 | 200 | 200 |
| 300 | 300 | 300 | 300 | 300 |
| 400 | 400 | 400 | 400 | 400 |
| 500 | 500 | 500 | 500 | 500 |

| Jobs/Occupation | Food | Beverages/Drinks | Feelings | Sports |
|-----------------|-----------|------------------|-----------|------------|
| Doctor | Egg | Coke | Sad | Soccer |
| Nurse | Bean | Juice | Happy | Basketball |
| Lawyer | Yogurt | Water | Angry | Volleyball |
| Trainer | Sandwich | Ice Tea | Depressed | Rowing |
| Psychologist | Hamburger | Lemonade | Annoyed | Rugby |

Above is an example of how a Jeopardy game should look before play begins. Once teams have been established, the first team will decide together which card they would like to choose. For example, the first member of the team will say, "We'll take 'Feelings' for 500." The teacher must then remove the 500 card under the "Feelings" category from the board and read aloud the word on the back of the card. According to the chart above the teacher would read the word, "Annoyed." The first player from the team must spell this word correctly in order to win the 500 points for his/her team. The player **may not** receive help from his/her teammates during this time. Players are only allowed to talk with one another when they are deciding which card to choose.

Study Tips for Students:

Study with a partner - with a parent or friend, have the partner say a word, practice by repeating the word once, spelling the word as fast as you can correctly, and then repeat the word one more time

Play a game - using a ball or jump rope practice spelling the word by jumping each time you say a letter or bouncing the ball each time you say a letter

Develop a hand game - practice clapping to the sound of the word. Clap for each syllable and then clap for each letter that you say

Websites for More Information:

Below are several links where teachers and volunteers can go to get different ideas and have puzzles and games automatically created for them.

<http://www.eslhq.com> - here you must register, but it is free, and then you have access to a lot of different games and activities to help students learn.

<http://www.esldesk.com/spelling> - here you can access tons of different spelling and vocabulary materials for students

★ ★ ★ SPELLING ★ ★ ★
B I N G O

| | | | | |
|--|--|-------------------------|--|--|
| | | | | |
| | | | | |
| | | ★ FREE SPACE ★ | | |
| | | | | |
| | | | | |

© 2003 by Education World. Education World grants users permission to reproduce this work sheet for educational purposes only.



Proper Names of Letters

When it comes to spelling words in English, it is important that students understand the difference between the sound of an English letter and the name of the letter. When spelling words during competition, only the names of the letters will be accepted. Sounds of the letter will be considered incorrect, even if the sound is from the correct letter, the student must say the name of the letter.

| | |
|------------------|---------------|
| English Alphabet | "ей" |
| Aa | "би" |
| Bb | "си" |
| Cc | "ди" |
| Dd | "и" |
| Ee | "еф" |
| Ff | "джи" |
| Gg | "ейч" |
| Hh | "ай" |
| Ii | "джей" |
| Jj | "кей" |
| Kk | "ел" |
| Ll | "ем" |
| Mm | "ен" |
| Nn | "о" |
| Oo | "пи" |
| Pp | "кю" |
| Qq | "ар" |
| Rr | "ес" |
| Ss | "ти" |
| Tt | "ю" |
| Uu | "ви" |
| Vv | "даблю" |
| Ww | "екс" |
| Xx | "уай" |
| Yy | "зий" / "зед" |
| Zz | |

Name



**Bulgarian National English
Spelling Bee**



NATIONAL SPELLING BEE

Official Rules and Guidelines

Section A

Basic Rules of Competition

1. Spellers must be between the ages of 9 and 14 and must not have already passed 8th grade.
2. The **host** must call out the number of the first speller.
3. The speller must stand next to his/her own seat or walk to the microphone** if necessary.
4. The **announcer** will slowly pronounce the word out loud.
5. The speller must first repeat the word to the announcer before spelling the word.
6. The speller has two minutes and thirty seconds (2 min 30 sec) to spell the word.
7. During this time, the speller may ask the announcer to: repeat the word, or define it
8. Should the speller ask for the definition of the word, the **host** may provide the definition in Bulgarian.
9. Once the speller begins spelling the word: he/she may not correct any letter misspelling, she/she may start over and spell the word from the beginning, but must retrace the letters previously spelled aloud and in the same order in which they were spelled.
10. Once he speller has completed spelling the word, he/she must repeat the word aloud to indicate that he/she is indeed finished.
11. Spellers may use the British or American spellings of the words.
12. Spellers must use the correct name of the letter. Using the sound of the letter is not accepted and will result in disqualification.
13. If the announcer determines that the word is spelled correctly he will tell the speller that he/she is "correct" and to take his/her seat. If the word is misspelled, the announcer will tell the speller that the word is "incorrect". The speller must then take in the area designated for disqualified spellers
14. Competition rules continue until there are just **two** spellers left.



T-W-E-E-T

Section B:

When Two Spellers Are Left in Competition

The rules for elimination during competition change slightly when only two spellers remain

1. If the first of the last two spellers misspells a word, he/she is not eliminated. Instead, the second speller is given a chance to correctly spell the misspelled word. If the second speller spells the word correctly, he/she is given a new word to spell. If the second speller also spells the new word correctly, he/she will be declared the champion.
2. Should the second speller spell the misspelled word correctly, but misspell the new word given, then the first speller will have a chance to correctly spell this misspelled word. If the first speller spells this word correctly, he/she is given a new word to spell. If the first speller also spells the new word correctly, he/she will be declared the champion.
3. If the first speller misspells the word and the second speller also misspells the same word, then the announcer will provide a new word for the first speller to spell.
4. Then the aforementioned process continues until a champion is declared.
5. Decisions made by the host and/or announcer are final and cannot be appealed.



IMPORTANT NOTE: Any participant or non-participant caught cheating or assisting someone to cheat will be disqualified and/or banned from the competition.

*Disqualification occurs when:

- a speller misspells a word (only applies to Section A above)
- a speller does not abide by the rules and guidelines of competition
- a speller exceeds the allotted time to spell any given word
- a speller ignores a request by an official, such as the host or announcer
- it is deemed necessary by the host or announcer

LOCAL COMPETITION

Competitions must be held within the first week of March, between TBA

1. Competitions must be hosted by a local Bulgarian with assistance from a Peace Corps volunteer.
2. Announcer of the competition must be a PC volunteer or a native English speaker.
3. On the day of competition, the host and volunteer must make sure:
 - each speller is assigned a number to wear on his/her clothing. Student's name and assigned number to be documented.
 - spellers are seated in ascending numeric order.
 - the room has designated seating for disqualified* spellers.
 - the host and volunteer each have a copy of: the list of words to be used; an English/Bulgarian dictionary; a copy of the *Official Rules and Guidelines of the National Spelling Bee*.
4. The competition must begin on time.
5. The host must first read aloud the *Official Rules of the National Spelling Bee*.
6. The competition will begin once the *Official Rules* have been read and the host has taken his/her seat next to the volunteer. The host and volunteer must be seated facing the spellers.
7. This is not a closed competition. The school/ host and/or volunteer to determine who is a permitted in the spelling area.
8. Competition may be held in any local venue approved by the school/host and/or volunteer.
9. Date, time, and place of competition must be determined by school/teacher in cooperation with the volunteer.
10. There is no official dress code; however, it is advised to dress appropriately.
11. The host must audio record the competition and announce each speller by their number.

Results of competition must be submitted by TBA